

CD293 SERIES



ALUMINUM ELECTROLYTIC CAPACITORS



- Load life 2000 hours at 85°C

SPECIFICATIONS

Item	Characteristics																																									
Operating Temperature Range(°C)	-40~+85	-25~+85																																								
Rated Voltage Range (V)	10~400	450																																								
Nominal capacitance range (μF)	68~82000																																									
Capacitance Tolerance(20°C,120Hz)	±20%																																									
Leakage current (μA)	I≤0.01CV or 1.5mA whichever is smaller (at 20°C ,after 5 minutes) C: Nominal Capacitance (μF) V: Rated Voltage (V)																																									
Dissipation Factor(20°C,120Hz)	<table border="1"> <thead> <tr> <th>Rated voltage (v)</th> <th>10~16</th> <th>25</th> <th>35~50</th> <th>63</th> <th>80~100</th> </tr> </thead> <tbody> <tr> <td>Cap (μF)</td> <td></td> <td></td> <td></td> <td></td> <td></td> </tr> <tr> <td>≤2700</td> <td>-</td> <td>-</td> <td>0.20</td> <td>0.15</td> <td>0.15</td> </tr> <tr> <td>3300~4700</td> <td>-</td> <td>0.35</td> <td>0.25</td> <td>0.20</td> <td>0.15</td> </tr> <tr> <td>5600~6800</td> <td>0.40</td> <td>0.35</td> <td>0.30</td> <td>0.20</td> <td>0.20</td> </tr> <tr> <td>≥8200</td> <td>0.40</td> <td>0.35</td> <td>0.35</td> <td>0.25</td> <td></td> </tr> </tbody> </table>						Rated voltage (v)	10~16	25	35~50	63	80~100	Cap (μF)						≤2700	-	-	0.20	0.15	0.15	3300~4700	-	0.35	0.25	0.20	0.15	5600~6800	0.40	0.35	0.30	0.20	0.20	≥8200	0.40	0.35	0.35	0.25	
	Rated voltage (v)	10~16	25	35~50	63	80~100																																				
Cap (μF)																																										
≤2700	-	-	0.20	0.15	0.15																																					
3300~4700	-	0.35	0.25	0.20	0.15																																					
5600~6800	0.40	0.35	0.30	0.20	0.20																																					
≥8200	0.40	0.35	0.35	0.25																																						
	<table border="1"> <thead> <tr> <th>Rated voltage (v)</th> <th>160~200</th> <th>250~450</th> </tr> </thead> <tbody> <tr> <td>ΦD (mm)</td> <td></td> <td></td> </tr> <tr> <td>22~30</td> <td>0.10</td> <td>0.15</td> </tr> <tr> <td>35</td> <td>0.12</td> <td>0.15</td> </tr> </tbody> </table>						Rated voltage (v)	160~200	250~450	ΦD (mm)			22~30	0.10	0.15	35	0.12	0.15																								
Rated voltage (v)	160~200	250~450																																								
ΦD (mm)																																										
22~30	0.10	0.15																																								
35	0.12	0.15																																								
Temperature Stability(120Hz)	<table border="1"> <thead> <tr> <th>Rated voltage (v)</th> <th>10</th> <th>16~35</th> <th>50~100</th> <th>160~200</th> <th>250~400</th> <th>450</th> </tr> </thead> <tbody> <tr> <td>Impedance</td> <td></td> <td></td> <td></td> <td></td> <td></td> <td></td> </tr> <tr> <td>Z-25°C/Z+20°C</td> <td>5</td> <td>4</td> <td>3</td> <td>3</td> <td>4</td> <td>4</td> </tr> <tr> <td>Ratio</td> <td></td> <td></td> <td></td> <td></td> <td></td> <td></td> </tr> <tr> <td>Z-40°C/Z+20°C</td> <td>18</td> <td>15</td> <td>10</td> <td>6</td> <td>8</td> <td></td> </tr> </tbody> </table>							Rated voltage (v)	10	16~35	50~100	160~200	250~400	450	Impedance							Z-25°C/Z+20°C	5	4	3	3	4	4	Ratio							Z-40°C/Z+20°C	18	15	10	6	8	
	Rated voltage (v)	10	16~35	50~100	160~200	250~400	450																																			
Impedance																																										
Z-25°C/Z+20°C	5	4	3	3	4	4																																				
Ratio																																										
Z-40°C/Z+20°C	18	15	10	6	8																																					
Load Life(+85°C)	Time		2000 hours																																							
	Leakage Current		Not more than the specified value.																																							
	Capacitance Change		Within ±20% of the initial value.																																							
	Dissipation Factor		Not more than 200% of the specified value.																																							
Shelf Life(+85°C)	Time		500 hours																																							
	Leakage Current		Not more than the specified value.																																							
	Capacitance Change		Within ±15% of the initial value.																																							
	Dissipation Factor		Not more than 200% of the specified value.																																							

After test : Rated voltage to be applied for 60 minutes, 24 to 48 hours before measurement.

DIMENSIONS

MM

MULTIPLIER FOR RIPPLE CURRENT

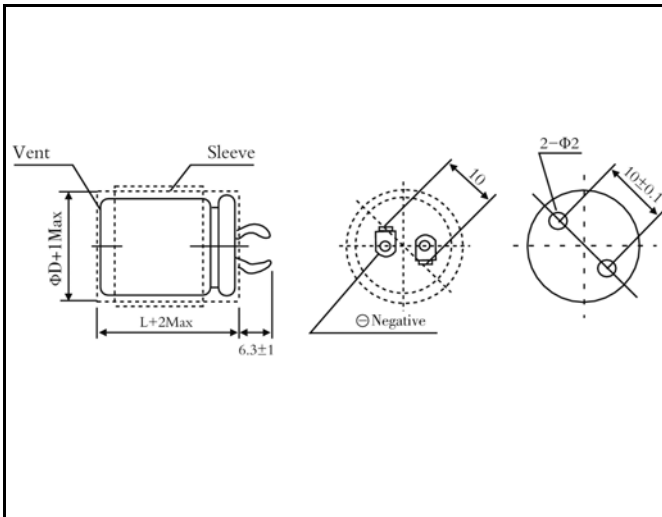

Frequency coefficient

Rated Voltage(V) \ Freq (Hz)	50	120	1K	10K	20K
≤50	0.95	1	1.10	1.15	1.15
63~100	0.95	1	1.16	1.30	1.33
≥160	0.95	1	1.20	1.50	1.55

Temperature coefficient

Rated voltage(V) \ Temperature(°C)	+40	+55	+70	+85
<160	2.1	1.8	1.5	1
≥160	1.7	1.5	1.3	1

CD293 SERIES



■ STANDARD RATINGS

WV(V)	10		16		25		35		50		63		80		100	
	Cap μF	Ripple (A)	Cap μF	Ripple (A)	Cap μF	Ripple (A)	Cap μF	Ripple (A)	Cap μF	Ripple (A)	Cap μF	Ripple (A)	Cap μF	Ripple (A)	Cap μF	Ripple (A)
22x25	10000	2.5	8200	2.2	5600	2.0	3300	1.8	2200	1.7	1500	1.6	1000	1.3	680	1.1
22x30	15000	3.2	10000	2.6	6800	2.3	3900	2.1	2700	1.9	2200	2.0	1200	1.5	820	1.2
22x35	18000	3.6	12000	2.9	8200	2.6	5600	2.3	3900	2.1	2700	2.2	1800	1.9	1200	1.6
22x40	22000	4.0	15000	3.3	10000	2.9	6800	2.9	4700	2.4	3300	2.3	2200	2.1	1500	1.8
22x45	-	-	18000	3.8	12000	3.3	-	-	-	-	3900	2.5	-	-	-	-
22x50	-	-	22000	4.2	-	-	8200	2.8	5600	2.5	-	-	2700	2.5	1800	2.1
25x25	15000	3.1	10000	2.6	6800	2.3	4700	2.2	2700	1.9	2200	2.0	1500	1.7	1000	1.4
25x30	18000	3.6	15000	3.3	10000	2.8	5600	2.3	3900	2.1	2700	2.3	1800	1.9	1200	1.6
25x35	22000	4.1	18000	3.7	12000	3.2	6800	2.6	4700	2.4	3300	2.3	2200	2.2	1500	1.7
25x40	33000	4.6	22000	4.2	15000	3.7	8200	2.8	5600	2.5	3900	2.6	2700	2.5	1800	2.0
25x45	39000	5.2	27000	5.0	-	-	10000	3.1	6800	2.8	5600	3.1	3300	2.8	2200	2.2
25x50	47000	5.8	-	-	18000	4.3	12000	3.5	8200	3.2	-	-	3900	3.1	2700	2.6
30x25	22000	4.1	15000	3.4	10000	3.0	6800	2.7	3900	2.4	3300	2.3	2200	2.2	1500	1.8
30x30	33000	4.8	22000	4.2	12000	3.4	8200	2.8	5600	2.5	3900	2.6	2700	2.5	1800	2.1
30x35	39000	5.3	27000	5.0	18000	4.2	10000	3.2	6800	2.8	5600	3.2	3300	2.8	2200	2.3
30x40	47000	6.0	33000	5.6	22000	4.8	12000	3.5	8200	3.0	6800	3.6	3900	3.2	2700	2.7
30x45	56000	6.7	39000	6.2	-	-	15000	4.1	10000	3.4	-	-	4700	3.6	3300	3.0
30x50	68000	7.5	47000	7.0	-	-	18000	4.6	12000	3.8	8200	3.7	5600	3.5	3900	3.4
35x25	33000	4.8	22000	4.4	15000	3.9	8200	2.9	5600	2.6	3900	2.7	2700	2.5	1800	2.2
35x30	47000	6.0	33000	5.6	18000	4.4	12000	3.6	8200	3.0	5600	3.3	3900	3.2	2200	2.5
35x35	56000	6.8	39000	6.3	22000	5.0	15000	4.1	10000	3.4	6800	3.7	4700	3.6	3300	3.1
35x40	68000	7.7	47000	7.2	33000	6.5	18000	4.7	12000	3.8	8200	3.8	5600	3.5	3900	3.4
35x45	82000	8.7	56000	8.0	39000	7.5	22000	5.3	-	-	10000	4.3	-	-	-	-
35x50	-	-	-	-	-	-	27000	7.0	15000	4.5	12000	4.8	6800	4.1	4700	4.0

WV(V)	160		180		200		250		315		350		400		450	
	Cap μF	Ripple (A)	Cap μF	Ripple (A)	Cap μF	Ripple (A)	Cap μF	Ripple (A)	Cap μF	Ripple (A)	Cap μF	Ripple (A)	Cap μF	Ripple (A)	Cap μF	Ripple (A)
22x25	330	1.3	270	1.2	220	1.1	180	0.94	100	0.67	82	0.64	68	0.55	-	-
22x30	390	1.5	330	1.4	330	1.4	220	1.1	150	0.85	120	0.82	100	0.70	68	0.57
22x35	560	1.9	470	1.7	390	1.6	270	1.2	180	0.96	150	0.94	120	0.79	100	0.72
22x40	680	2.1	560	1.9	470	1.8	330	1.4	220	1.1	180	1.1	150	0.90	120	0.80
22x45	-	-	-	-	560	2.0	390	1.6	270	1.2	220	1.2	180	1.0	-	-
22x50	820	2.5	680	2.3	-	-	470	1.8	-	-	-	-	220	1.1	150	0.95
25x25	390	1.5	390	1.5	330	1.4	220	1.1	150	0.85	120	0.81	100	0.70	-	-
25x30	560	1.9	470	1.7	390	1.6	300	1.4	180	0.96	150	0.94	150	0.89	100	0.73
25x35	680	2.2	560	2.0	560	2.0	390	1.6	220	1.1	220	1.2	180	1.0	120	0.83
25x40	820	2.4	680	2.2	680	2.3	470	1.8	270	1.3	-	-	220	1.2	150	0.95
25x45	1000	2.7	820	2.5	-	-	560	2.0	330	1.4	270	1.4	270	1.3	180	1.1
25x50	1200	3.1	1000	2.9	820	2.6	-	-	390	1.6	330	1.6	-	-	220	1.2
30x25	560	2.0	470	1.8	470	1.9	330	1.5	220	1.1	180	1.1	150	0.95	-	-
30x30	820	2.5	680	2.3	560	2.1	470	1.8	270	1.3	220	1.2	180	1.1	150	0.98
30x35	1000	2.8	820	2.6	680	2.4	560	2.0	330	1.4	270	1.4	220	1.2	180	1.1
30x40	1200	3.2	1000	2.9	820	2.7	680	2.3	390	1.6	390	1.7	270	1.4	220	1.3
30x45	1500	3.7	1200	3.3	1000	3.1	820	2.6	470	1.8	470	2.0	330	1.6	270	1.4
30x50	-	-	-	-	1200	3.4	-	-	560	2.0	-	-	390	1.8	-	-
35x25	820	2.4	680	2.2	560	2.0	470	1.9	270	1.3	220	1.3	180	1.2	180	1.2
35x30	1000	2.7	820	2.5	820	2.5	680	2.4	390	1.6	330	1.6	270	1.5	220	1.3
35x35	1200	3.0	1200	3.1	1000	2.8	820	2.6	470	1.8	390	1.8	330	1.7	270	1.5
35x40	1500	3.5	-	-	1200	3.2	1000	3.0	560	2.0	470	2.0	390	1.8	-	-
35x45	1800	3.9	1500	3.6	-	-	1200	3.4	680	2.3	560	2.3	470	2.1	390	1.9
35x50	2200	4.5	1800	4.1	1500	3.8	-	-	-	-	680	2.6	560	2.3	470	2.2

■ Ripple current: 85°C, 100Hz or 120Hz.

The specific capacitance and case size are available on request.